

# Scalable Storage Support for Data Stream Processing

Zoe Sebeopou and Kostas Magoutis

Institute of Computer Science (ICS)

Foundation for Research and Technology Hellas (FORTH)

Heraklion, Greece

# Data Stream Processing Model

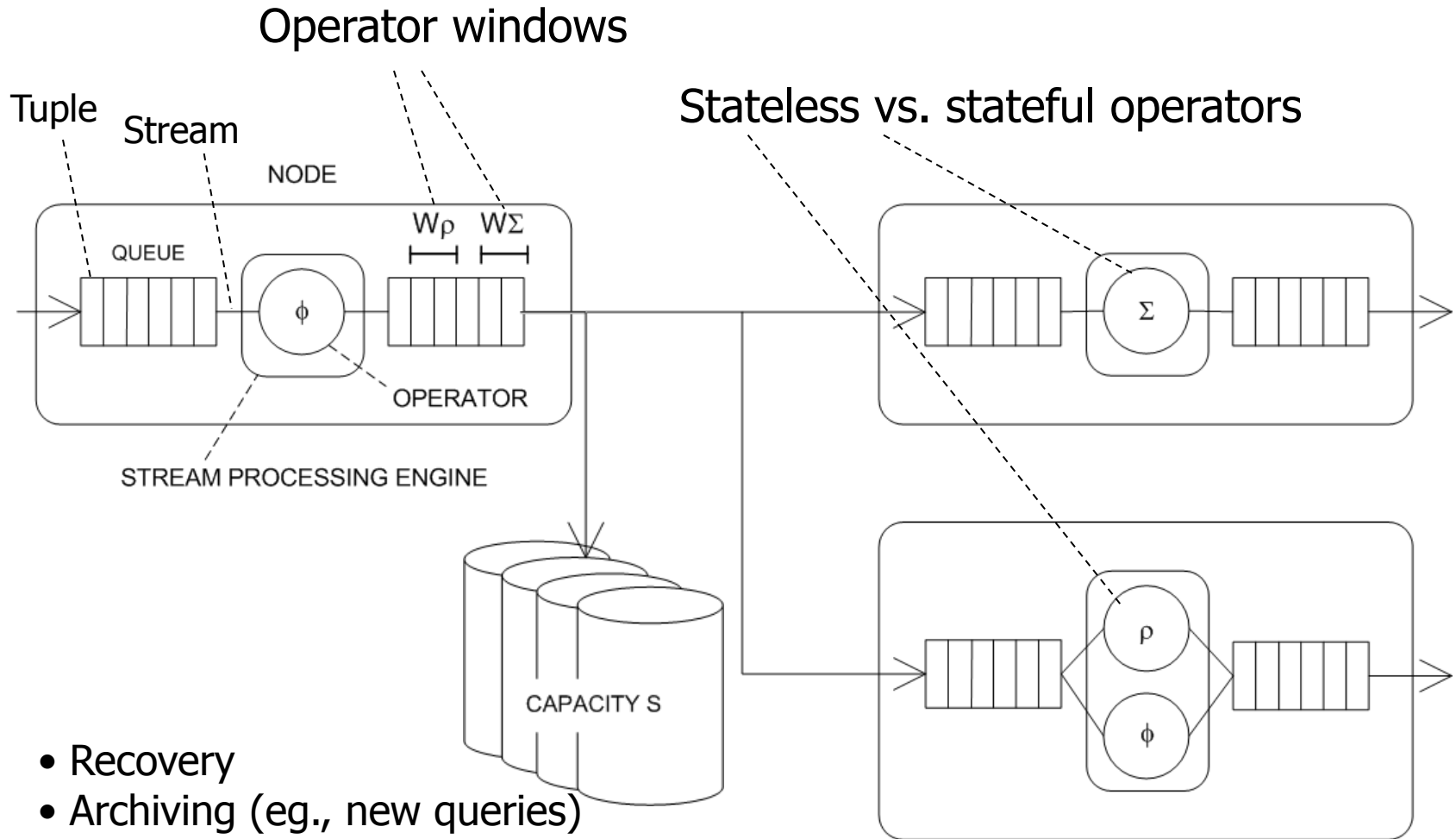

# Persistence Architecture

Borealis

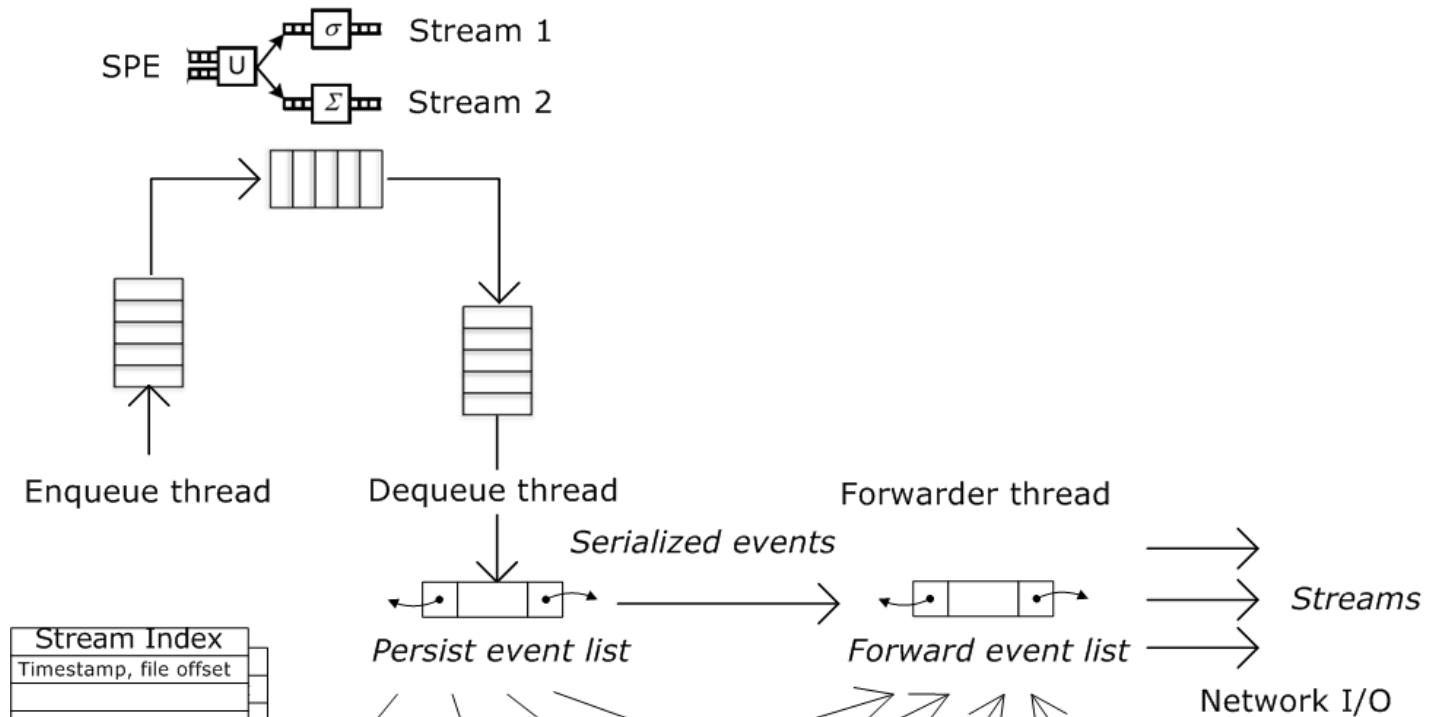

PVFS2

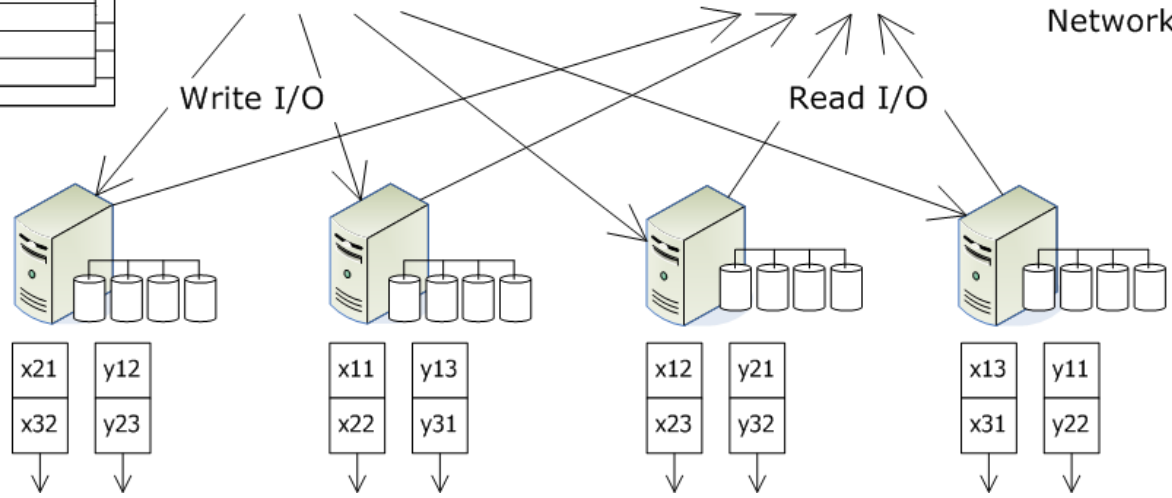

# Lessons Learned

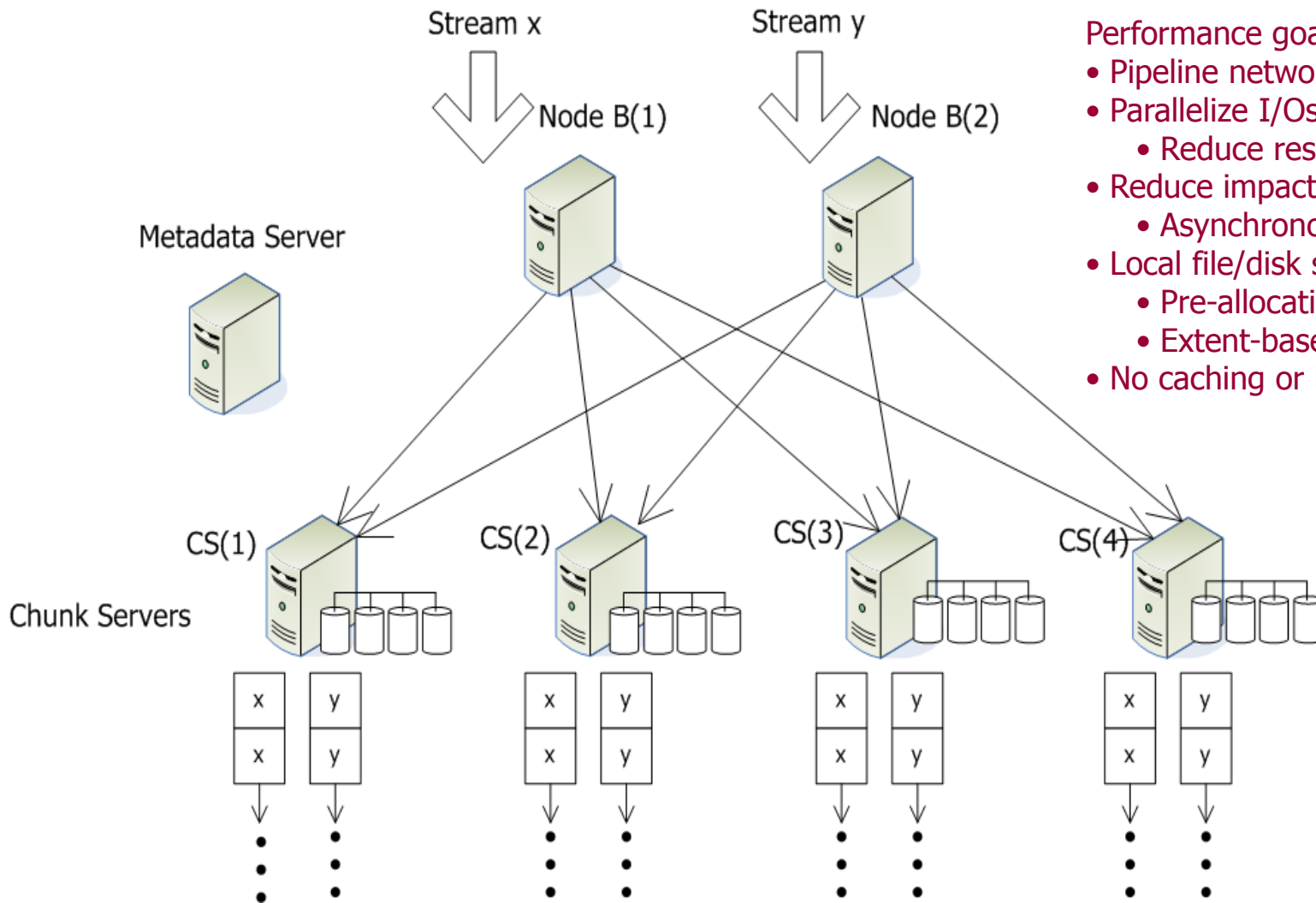

Performance goals :

- Pipeline network/disk
- Parallelize I/Os
  - Reduce response time
- Reduce impact of metadata
  - Asynchronous updates
- Local file/disk subsystem:
  - Pre-allocation
  - Extent-based allocation
- No caching or locking

# Evaluation

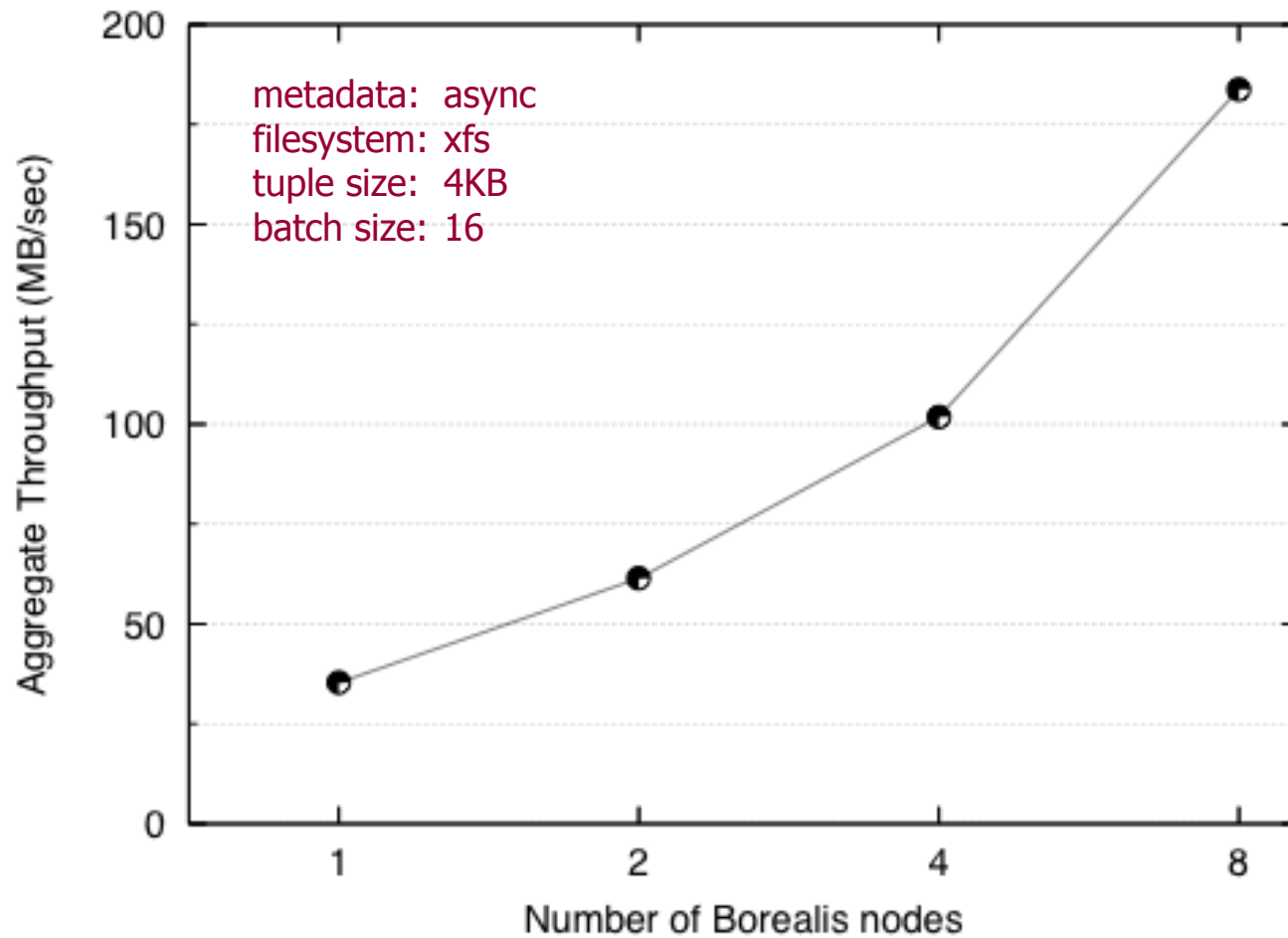

May 6, 2010

Thank you!

May 6, 2010

# Backup

May 6, 2010

# Evaluation

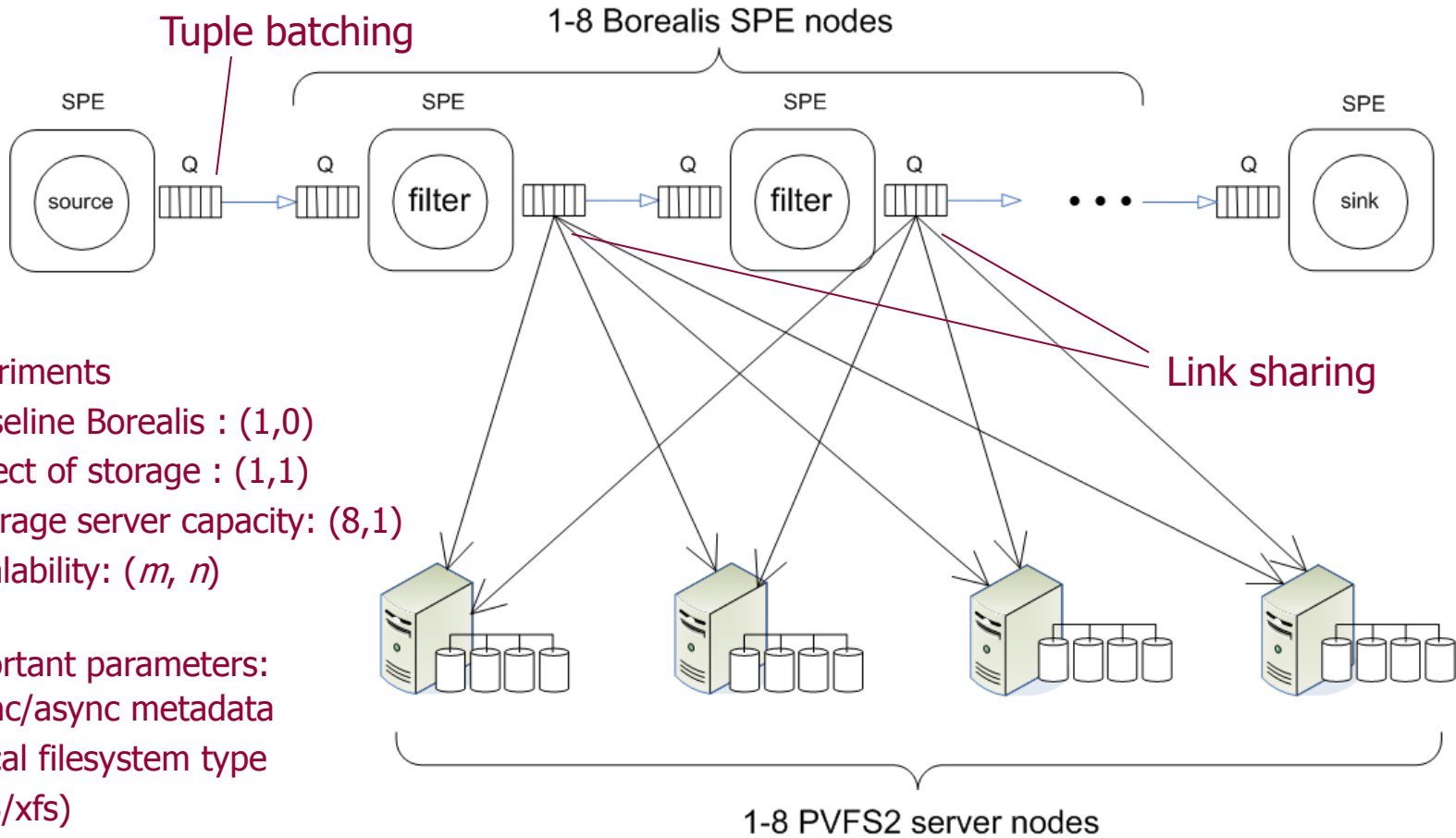

## Experiments

- Baseline Borealis : (1,0)
- Effect of storage : (1,1)
- Storage server capacity: (8,1)
- Scalability: ( $m, n$ )

## Important parameters:

- Sync/async metadata
- Local filesystem type (ext3/xfs)

# Experimental Testbed

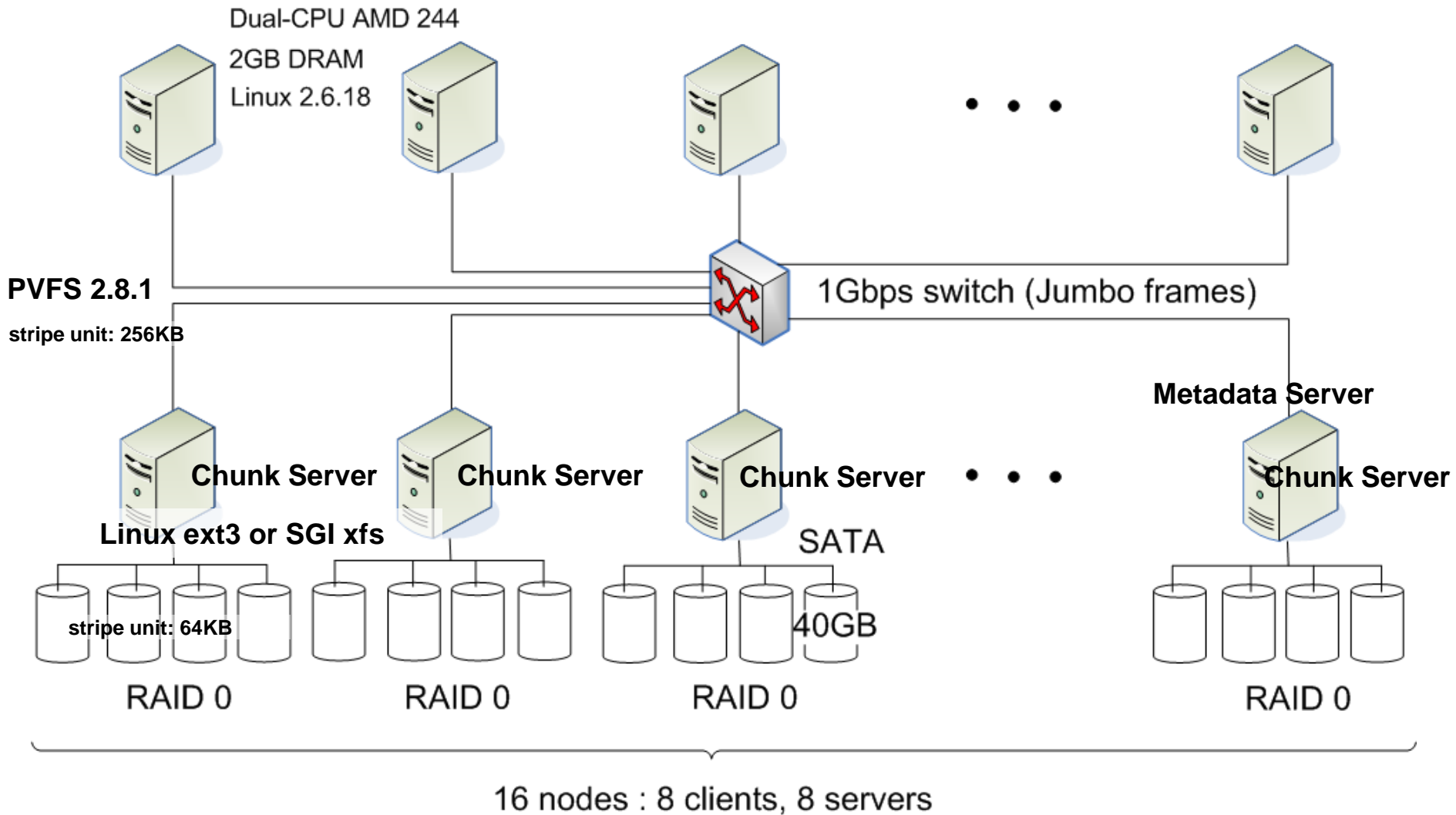

May 6, 2010

# Saturate PVFS2 server: (8, 1)

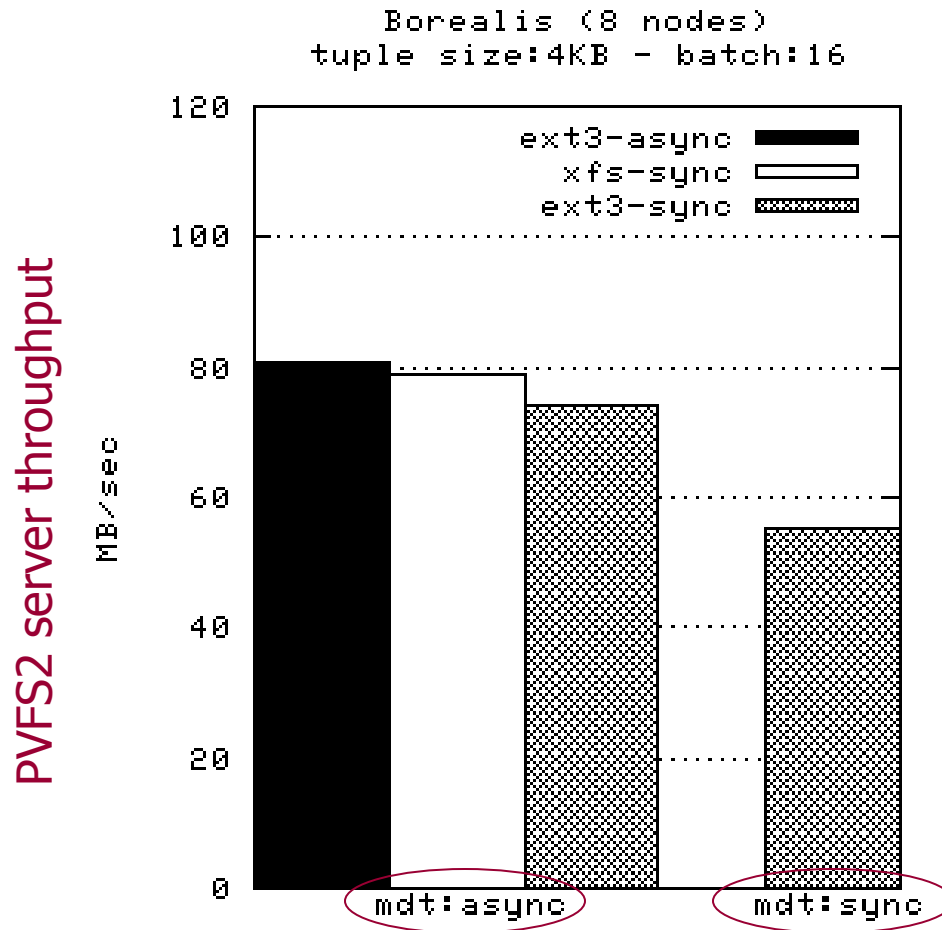

# Scalability: Borealis throughput

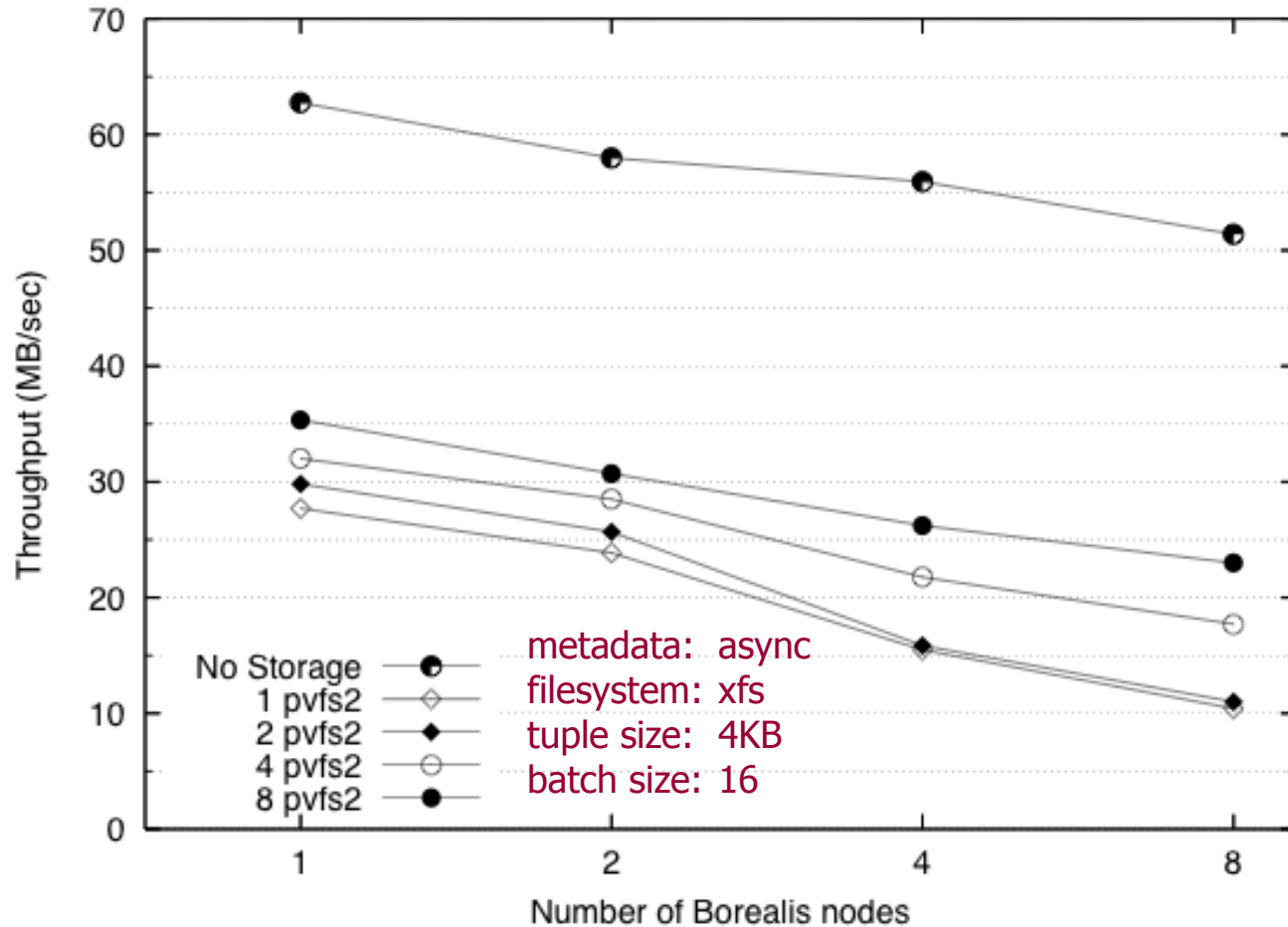

# Parallel file system

Metadata traffic (create, map name-handle, update size/atime/mtime)

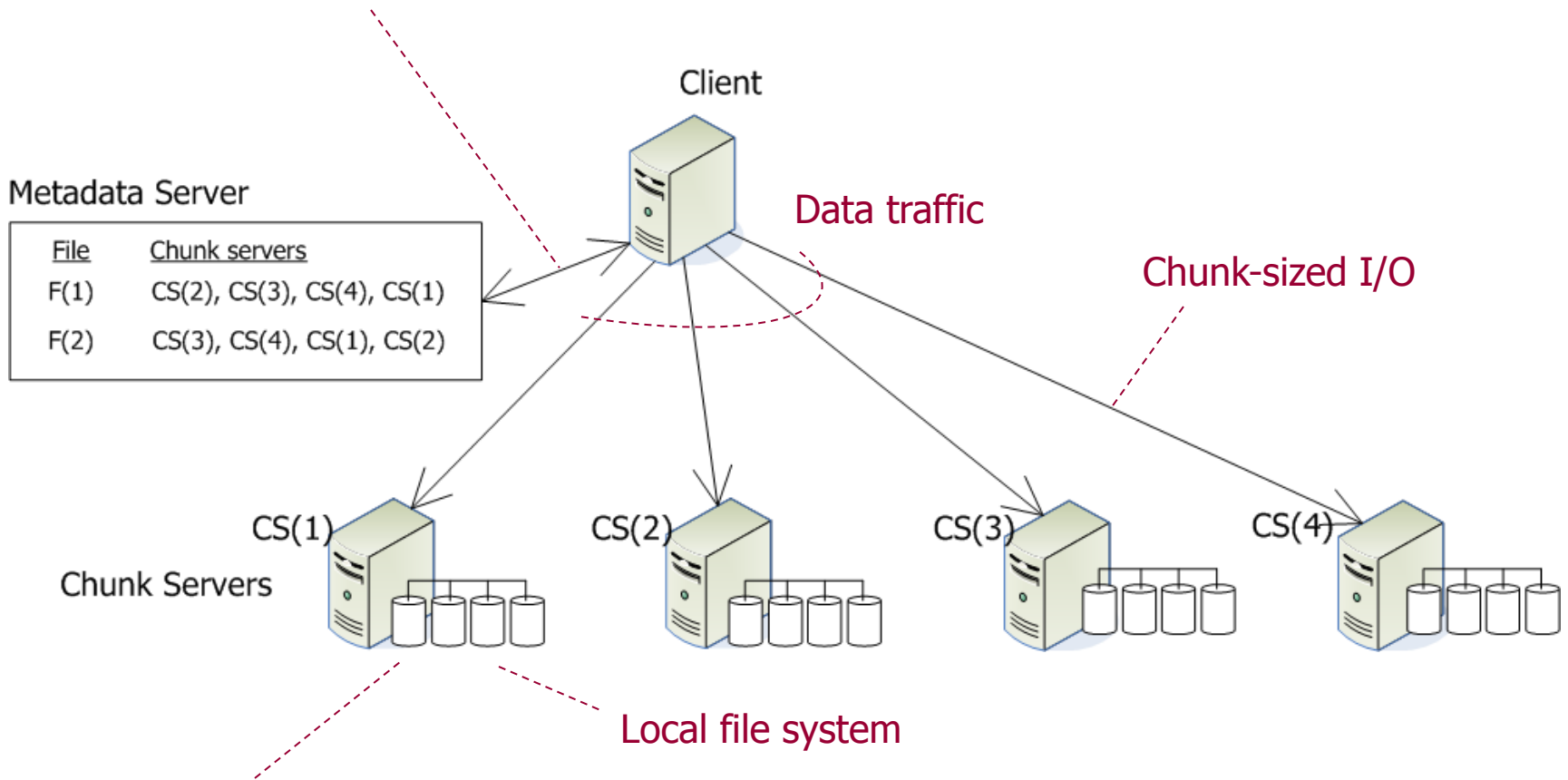

Local metadata traffic (create, map handle-local filename, update size/atime/mtime)

# Example application: Alarm correlation

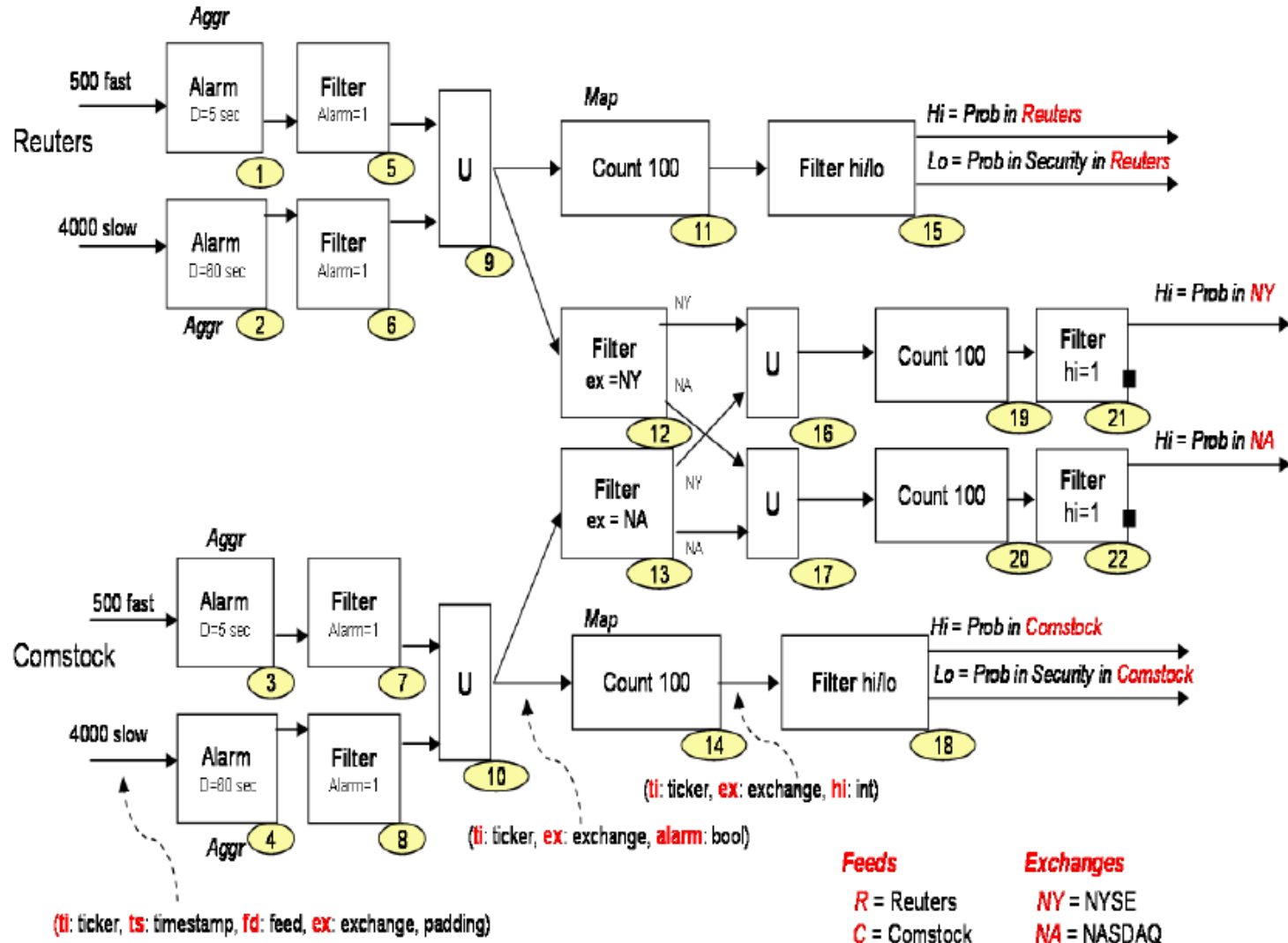

# PVFS2 Architecture

